

# COTTON UNIVERSITY

Panbazar, Guwahati, Assam-781001

[www.cottonuniversity.ac.in](http://www.cottonuniversity.ac.in) :: 0361-2733530 :: [registrar@ccsu.ac.in](mailto:registrar@ccsu.ac.in)

No. CU/EC/2019/066/Part-I/

dated:

## NOTICE INVITING TENDER

NIT No. 11 of 2022-23 Dt. 01.10.2022

### Press Notice

Cotton University invites sealed tenders in two bid systems from the interested and eligible reputed, experienced and financially sound contractors for **“Renovation of Toilet Blocks of Zoology, Botany and Indoor Stadium, Cotton University”**

Details of the bids may be seen and downloaded from the website [www.cottonuniversity.ac.in](http://www.cottonuniversity.ac.in). The last date of submission of tender will be 21.10.2022 till 14:00 hrs.

All terms and conditions will be as per the Bidding Documents.

The Press Notice will be a part of the Bidding Documents.

*Edham*  
Registrar 11/10/22

Memo No. CU/EC/2019/066/Part-I/ 4630-34

dated: 01/10/22

Copy for information to:

1. PS to the Vice Chancellor for kind information of Hon'ble Vice Chancellor.
2. Director, DIPR, GoA with a request to publish the above advertisement (softcopy enclosed) in immediate one issue of The Assam Tribune and The Amar Asom, and submit the bills in triplicate for release of payment
3. Finance Officer, CU
4. ✓ System Manager, CU for uploading the entire bid document in University website.
5. Office file.



**COTTON UNIVERSITY**  
Panbazar, Guwahati- 781001  
Assam, India  
Website: [www.cottonuniversity.ac.in](http://www.cottonuniversity.ac.in)

### **Notice Inviting Tender**

Tenders are invited from established contractor with proper experience for the work mentioned below,

Sl. No.	NIT No. & Date	Particulars	Estimated Amount Rs.
1	NIT No.-11 of 2022-23 Dated: October, 01 <sup>th</sup> , 2022	" Renovation of Toilet Blocks of Zoology, Botany and Indoor Stadium, Cotton University "	22.04 Lakh

The details are provided in the bid document which will be available and can be downloaded from the portal <http://cottonuniversity.ac.in> from 15:00 hrs of 02<sup>th</sup> October, 2022. Last date of submission is 21<sup>th</sup> October, 2022 up to 14:00 hrs. and the technical bid will be opened on same day at 15:00 hrs.

Sd/-  
Registrar

*Handwritten signature and date: 1/10/22*

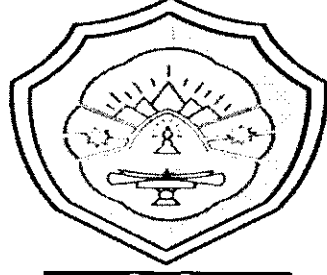

अप्रमत्तेन वेद्व्यम्

**COTTON UNIVERSITY**

**TENDER DOCUMENT**

**FOR**

**RENOVATION OF TOILET BLOCKS OF ZOOLOGY, BOTANY  
AND INDOOR STADIUM**

**PART - I**

**TECHNO-COMMERCIAL BID**

**NIT No. 11 Dt. 01.10.2022**

*Handwritten signature and date: 11/10/22*

**COTTON UNIVERSITY  
PANBAZAR,  
GUWAHATI – 781001**

**NOTICE INVITING TENDER No: 11**

Sealed tenders in two-bid-system are invited for and on behalf of the Cotton University for  
"RENOVATION OF TOILET BLOCKS OF ZOOLOGY, BOTANY AND INDOOR STADIUM"

**Key details of the tender are furnished below-**

Notice inviting tender No.	11
Name of the work	"RENOVATION OF TOILET BLOCKS OF ZOOLOGY, BOTANY AND INDOOR STADIUM"
Cost of tender document	Rs 1000.00
Estimate Amount	Rs. 22,04,000.00
Last date and time of receipt of tenders	21.10.2022 up to 14.00Hrs
Date and time of opening of technical bid	21.10.2022. 15.00 Hrs
Date and time of opening of price bid	Will be intimated to the technically qualified bidders through email.
EMD	Rs. 44,080.00 for General Category ( 2%) Rs. 22,040.00 for Reserved Category (1%)
Completion period	60 Days

*Handwritten signature*

## Terms and Conditions:

1. Price bid of only qualified contractors will be opened in presence of authorized bidder's representatives who choose to attend the opening of tender on the above specified date, time
2. In case the day of submission of the tenders happens to be holiday on account of Govt. notification, the submission & opening of the tenders shall automatically be extended to the next working day, the times specified remaining the same.
3. Any future clarification(s) and / or corrigendum (s) shall be communicated through the website. Therefore, the bidders are requested to regularly visit the website.
4. The University reserves the right to amend or withdraw any of the terms and conditions contained in the Tender Document including quantity of items to be supplied or to reject any or all tenders without giving any notice or assigning any reason. The decision of the University shall be final in this regard.
5. **Validity period:** The rates quoted in the tender shall remain valid for 180 days.
6. Complete Tender Document may be downloaded from the university's website [www.cottonuniversity.ac.in](http://www.cottonuniversity.ac.in). Interested contractors who have credentials to fulfil the Eligibility/ Qualifying criteria as detailed in item-9 below. Tenderers are requested to submit tenders as per the formats and guidelines given in this document.
7. **Submission of EMD and cost of tender document:** The EMD and the cost of tender documents shall be submitted in the form of Demand draft/ Banker's cheque in favour of "Registrar, Cotton University" payable at Guwahati. The EMD and the cost of tender document shall be submitted in the envelope containing the Technical Bid. **Tender submitted without EMD and cost of tender document shall be summarily rejected and such tenders will not be considered for technical evaluation. However participant Tenderers for NIT No 09 of 2022-23 dtd. 08/09/2022 are exempted from submission of Cost of Tender and EMD.**
8. Bidders are expected to examine all instructions, forms, terms & conditions, and specifications in the bidding document. Failure to furnish all information prescribed in the bidding documents or submission of bids not substantially responsive to the bidding documents in every respect may result in the rejection of the bid.
9. **Eligibility/ Qualifying criteria:**
  - i) The bidders must be registered with APWD /CPWD/MES/ and other Govt. /Semi Govt. / Govt. Undertaking of not less than Class-II registration. Latest registration certificate must be enclosed with the bid.
  - ii) The bidders must have experience in execution and completion of similar work
  - iii)
    - a) Single work order of 80% of tender value during last 5 years
    - b) Double work order of 50% each of tender value during last 5 years.
  - iv) Average turnover in last 3 (three) years should be at least Rs. 10 lakhs.

V) Similar works means Civil works related to construction of building or Universal Toilet blocks. In case of composite work such as building BOQ related

*blsh*

to Toilet portion water and sanitary works to be submitted. The value of work is as detailed in Clause 9 (iii).

AND

VI ) Experience related to Renovation of Universal toilet along with Water supply and Sanitary works

**10. Submission of Bid will be manual and as follows:-**

**Tender shall be submitted in the following manner in separate sealed covers duly superscripted as explained in the special conditions of contract:**

**Part I – Techno-Commercial Bid**

**Part II – Price Bid**

**The EMD and the cost of tender document shall be deposited along with Part – I, i.e. Techno-Commercial Bid.**

Tenders shall be submitted as per detailed instructions given in the Special Instructions to Tenderer, to **The Registrar, Cotton University, Panbazar, Guwahati-781001**, so as to reach within the specified time of the last date of submission of the tender.

11. Late tenders will not be considered. No responsibility will be taken for postal delay or non -receipt of Bid documents. Unsealed bids or bids sent by FAX or e-mail, will not be considered.
12. **Evaluation of the techno-commercial bids:** The techno- commercial bids shall be evaluated strictly on the basis of eligibility criteria specified in clause-9 above and also elaborated in the special conditions of contract and technical specifications. Fulfilment of the eligibility criteria shall be based on the information, documents furnished along with the tender. It is the responsibility of the bidder to submit all the relevant information supported with necessary document to establish the fulfilment of each of the eligibility criteria in full, whether specifically asked to be filled up in the attached formats/ annexure or not. The bid shall be liable for rejection for non fulfilment or partial fulfilment of any of the eligibility criteria.
13. The Price Bids of only the eligible bidders shall be opened in presence of their authorized representatives, on a date, to be intimated to them (the eligible bidders). The price bids of only those bidders will be opened whose bids have been found eligible as per the terms mentioned in the Special Conditions of Contract. Interested bidders are requested to carefully study the eligibility criteria stated in the Special Conditions of Contract. All eligibility conditions have to be satisfied on the date of submission of the bid and not on a later date. The date and time of opening of the technical bids/ price bids will not be postponed due to the non-presence of any bidder or his authorised representative.
14. **Rejection of Bids:** Canvassing by the bidder in any form, unsolicited letter and post tender correction, unsigned bids shall be summarily rejected and may lead to forfeiture of EMD. Conditional tenders will also be rejected. Cotton University reserves the right to cancel/reject any/all the tenders without assigning any reason thereof.
15. **Completion period:** The successful bidder will have to complete the works within Sixty (60) days from the date of receipt of work order.
16. The authority of Cotton University may accept or reject any or all the bids in part or in full without assigning any reason and does not bind itself to accept the lowest bid. The University, at its discretion, may change the quantity / upgrade the criteria / drop any item or part thereof at any time before placing the Purchase Order.
17. A bid submitted with false information will not only be rejected but also the EMD submitted by the bidder will be forfeited. Further, the bidder may be debarred from participation in future tendering process.

Registrar,  
Cotton University



**COTTON UNIVERSITY**

**Submission of Tender**

**From :.....**

**To  
The Registrar  
Cotton University  
Panbazar, Guwahati – 781 001**

I / We hereby tender for execution of the work of “ Renovation of toilet blocks of Zoology, Botany and Indoor Stadium” as per tender within the time schedule mentioned therein as separately signed and accepted by me / us, at the schedule of rates quoted by me / us for the whole work in accordance with Notice Inviting Tender, General Conditions of Tender, Special Instructions to Tenderer, Technical Specifications, workmanship, drawings, other documents and papers, all as detailed in the tender documents.

1. It has been explained to me / us that the time stipulated for job and completion of works in all respects and in different stages mentioned in the “Time schedule” of completion of job and signed and accepted by me / us is the essence of the Contract. I / We agree that in the case of failure on my / our part to strictly observe the time of completion mentioned for jobs or any of them and to the final completion of works in all respects according to the schedule set out in the said “Time Schedule of Completion of Job”, I / We shall pay compensation to the Owners as per provision and stipulations contained in clause – 1.19 of General conditions of Tender and I / We agree to recovery being made as specified therein. In exceptional circumstances extension of time which shall always be in writing may, however, be granted by the Engineer-in-Charge at his entire discretion for some items of work, and I / We agree that such extension of time will not be counted for the extension of completion dates stipulated for job and for the final completion of works as stipulated in the said “Time Schedule” of Completion of Jobs.
1. I / We agree to pay the earnest money and security deposit and accept the terms and conditions laid down in the memorandum below in this respect.

*J. J. J.*

**MEMORANDUM**

(a) General description of work .....

(b) Earnest Money Rs.....  
(Rupees).....

The Earnest money is payable in the manner set out in para 5 below. The Earnest money, if the tender is accepted, will be retained against the security deposit when Earnest Money is paid in cash or demand draft only.

(d) Time allowed for starting work : Seven days from the date of issue of letter of acceptance of the tender

4. Should this tender be accepted I / We hereby agree to abide by and fulfill all terms and conditions referred to above and in default thereof, to forfeit and pay to the Owner or its successors or its authorized nominees such sums of money as are stipulated in conditions contained in Notice Inviting Tender and other tender documents.

5. If I / We fail to commence the work specified in the memorandum in para (3) above, or I / We fail to deposit the amount of security deposit specified in the Memorandum in para (3) above, I / We agree that the said Owner and its successors without prejudice to any other right or remedy be at liberty to forfeit the said earnest money in full otherwise the said earnest money shall be retained by Owner, towards the security deposit specified in para (3) above. The said Owner shall also be at liberty to cancel the notice of acceptance of tender if I/We fail to deposit the security amount as aforesaid or to execute an agreement or to start work as stipulated in the tender documents.

I / We enclose herewith evidence of my/ our experience of execution of work of similar nature and magnitude carried out by me/ us in the prescribed proforma.

Date.....day of.....2022

Witness :

Name in Block Letters :  
Address :  
Firm

Signature of Tenderer(s),with the seal of





**PROPOSAL PARTICULARS & VENDOR INFORMATION**

1. Tenderer's complete Company Name & Address :
  
2. Tenderer's proposal no. :
3. Tenderer's proposal date :
4. Tenderer's proposal validity period :
5. Whether Earnest Money & Cost of Tender Document deposited? If so, furnish amount, bank name & DD no-
  - a) EMD :
  
  - b) Cost of tender document :
6. Name and designation of the officer of the tenderer to whom all reference shall be made for expeditions technical co-ordination. :
7. Particulars of past experience of execution of similar projects furnished ? :
8. GST No :  
Copy of the GST Registration certificate enclosed? :
9. PAN No :  
Copy of PAN Card enclosed ? :
10. Audited balance sheet for last three financial years enclosed? :
11. IT Return for last three years enclosed? :
12. UDIN No. :
13. EPF Registration No :
14. Labour License No :

**Seal & Signature of the  
tenderer**

*balu*

## General conditions

### SECTION – A

1. Definition of Terms: In the contract document as herein defined where the context so admits, the following words and expressions will have the following meanings:

1.1 "The Owner" means The Cotton University, Guwahati- 781001.

1.2 "The Contractor" means the person or the persons, firm or company whose tender has been accepted by the Owner and includes the Contractor's legal representative, his successor and permitted assignees.

1.3 The "Officer-in-Charge" shall Mean the person designated as such by the Owner and shall include those who are expressly authorized by the Owner to act for and on his behalf for operation of this contract.

1.4 The "Work" shall mean works to be executed in accordance with the contract or part thereof as the case may be and shall include all extra additional altered or substituted works as required for the purpose of the contract.

1.5 The "Permanent work" means works as handed over to the Owner by the Contractor on completion of the contract.

1.6 "Construction Equipment" means all applications and equipment of whatsoever nature for the use in or for the execution, completion, operation or maintenance of the work unless intended to form part of the Permanent work.

1.7 "Site" means the areas on which the permanent Works are to be execute or carried out and any other places provided by the Owner for purpose of the contract.

1.8 "Contract Document" means collectively the Tender Document, Designs, Drawings, Specifications, agreed variations, if any, and such other documents constituting the tender and acceptance thereof.

1.9 The "Contract" shall mean the Agreement between the Owner and the Contractor for the execution of the works including therein all contract documents.

1.10 The "Specification" shall mean the various technical specifications attached and referred in the tender documents. It shall also include the latest edition including all addenda/corrigenda of relevant Indian Standard Specifications published before entering into Contract.

1.11 "The Drawings" shall include maps, plans and tracings or prints thereof with any modifications approved in writing by the Engineers-in-Charge and such other drawings as may required , from time to time, or furnished or approved in writing by the Officer-in-Charge.

1.12 The "Tender" means the tender submitted by the Contractor for acceptance by the Owner.

1.13 The "Alteration Order" means an order given in writing by Officer-in-Charge to effect additions to or deletion from and alteration in the work.

1.14 The "Completion Certificate" shall mean the certificate to be issued by the Owner when the works have been completed to his satisfaction.

1.15 The "Final Certificate" in relation to a work means the certificate issued by the Owner after the period of liability is over.

1.16 The "Defect Liability Period" in relation to a work means the specified period from the date of issue of completion certificate upto the date of issue of final completion certificate during which the Contractor stands responsible for rectifying all defects that may appear in the works.

1.17 The "Appointing Authority" for the purpose of arbitration shall be the Registrar, Cotton University or any other person so designated by the Owner.

*Ellis*

1.18 'Tendering period' means the period from the date of invitation of tender to date of submission of tender.

## **SECTION – B**

### **2. GENERAL INFORMATION**

2.1 Location and Accessibility of Site: Cotton University, Panbazaar, Guwahati-781001.

2.2 Scope of Work : The scope of work is defined in the special conditions of Contract and specifications. All design, drawing, materials required for the work shall be approved by the appropriate authority prior to procurement and use.

2.4 Power Supply: The Contractor will make his own arrangement for his requirement of power to carry out the work. Owner will not be supplying power for this work. All the works by the Contractor in this regard will be done as per the Indian Electricity Act and rules framed there under and as approved by the Officer-in-Charge.

2.5 Site clearance: On completion of the works undertaken by the Contractor, he shall remove all temporary works erected by him and have the site cleaned as directed the Officer-in-Charge.

## **SECTION – C**

### **GENERAL INSTRUCTIONS TO TENDERER**

#### **3. Submission of Tender:**

3.1 Tender must be submitted in original and without making any additions, alterations and as per details given in other clauses in tender document.

3.2 Addenda/Corrigenda to this tender document, if issued, must be signed and submitted along with the tender document. The tenderer should write clearly the revised quantities along with rates and should price the work based on revised quantities when amendments for quantities are issued in addenda.

3.3 The Original tender copy marked duly completed and signed on each page should be submitted along with the offer.

3.4 The tender should be placed in doubled sealed covers super-scribing the full name of the work, due date of opening .The full name, postal address of the tenderer shall be written on the bottom left corner of the sealed cover.

#### **4. Documents to be submitted**

(i) Complete set of the "Original Copy" of the tender document as sold duly filled in and signed by the tenderer as prescribed in different clauses of the tender document with all addenda/corrigenda issued duly signed.

(ii) Earnest money in the manner specified in.

(iii) Copy of income tax return along with audited balance sheet for the last three consecutive years.

(v) Details of work of similar type and magnitude carried out by Tenderer.

(vi) The tenderer shall submit copies of PAN, GST registration under EPF an MP Act1952, ESIC, whatever is applicable to this contract.

(vii) Turnover statement for the last five years certified by a chartered accountant and having UTR number to be submitted.

*Babun*

## SECTION – D

### 4. SPECIAL CONDITION

4.1) The materials, design and workmanship shall satisfy the relevant Indian Standards, the job specifications contained herein and codes referred to. Where the job specifications stipulate requirements in addition to those contained in the standard codes and specifications stipulate requirements in addition to those contained in the standard codes and specifications these additional requirements shall also be satisfied.

4.3) Time of performance: Period of Completion 60 Days from the date of issue of LOI or acceptance.

4.4) Extension of Time If the Contractor shall desire an extension of the time for completion of the work on the grounds of his having been unavoidably hindered in its execution or on any other grounds, he shall apply in writing to the Officer-in-Charge within ten days of the date of the hindrance on account of which he desires such extension as aforesaid, and the Officer-in-Charge shall, after consulting the competent authorities, is satisfied that reasonable grounds have been shown thereof, authorize such extension of time as may, be necessary or proper without any extra cost / liability to the Owner. No compensation for a resources, labourer etc. brought to site in idle period will be paid to contractor.

4.9) Defect Liability period: the defect liability period is 6 months from the date of issue of completion certificate. During the period any constructional defects has to be rectified at the cost of the contractor. The retention of money will be issued after issue of final completion certificate.

4.10) Payment Schedule: The payment schedule will be on Item rate basis. All statutory deductions applicable in the contract will be made from the bills.

4.11) Court Jurisdiction: Court Jurisdiction within the city of Guwahati, Kamrup (metro). No arbitration in any form will be entertained.

## SECTION – E

### 5. Other Condition of Contractor

5.1) The issue of tender paper to a contractor does not automatically mean that the tenderer is considered qualified for the price part of the bid. Qualifying criteria stated above are for participation / issue of tender document only. Technical bids of the tenders which fulfill the above qualifying criteria and which encloses all required documents and deposits (EMD & Cost of tender document) as specified shall be considered for technical evaluation as per procedures and norms decided by the university.

5.2) The acceptance of tender will rest with the authority of Cotton University who does not bind itself to accept the lowest tender and reserve to itself the right to reject any or all the tenders received without assigning any reason thereof.

5.3) For all clarifications regarding site conditions, items of works or any other related to tender Executive Engineer, CU, may be contacted during office hours.

5.4) In case, the day of submission of the tender happens to be a holiday on account of Govt. notification and tender cannot be opened; the tender shall be opened on the next working day at 3.00 p.m.

5.5) The tender document shall be submitted in two parts as follows:

PART-A : This packet shall contain the Technical Bids comprising of NIT, General Conditions of Contract, Special Conditions of Contract, Technical specifications, drawings, testimonials and other supporting documents, any other matter the tenderer wish to submit duly signed with official seal etc. This shall be marked as, "TECHNICAL BID" and properly sealed. **The earnest money to be put in a separate sealed envelope.**

PART-B: This packet shall contain the Price Bids comprising the price against the tender

5.6) Part-A tenders shall be opened on the date and time as mentioned above. But price bids of only of those tenderers whose technical bids (Part-A) are found acceptable shall be opened on a later date. Prior notification shall be given to all tenderers who qualify for opening of the PRICE BIDS to enable them to attend the opening of the Price bids. Part-B of the tender of those tenderers who do not qualify for opening of the Part-B shall be returned.

5.7) Only authorized person(s) to attend tender opening. All the bidders shall send their representative(s) to attend tender opening with proper authorization during opening of the tenders.

5.8) Earnest money: The Earnest money should be in the form of Demand Draft in favour of Cotton University, payable at Guwahati, and to be put in a separate Sealed Envelope inside the Technical Bid Packet. Earnest Money to unsuccessful tenderers shall be returned against the application.

5.9) Tenderer should quote for the work accordingly. The quoted rates shall be firm and should include all taxes, royalties, duties, octroi, excise, freight, works contract tax applicable in the state etc. whatsoever from time to time.

5.10) A sum of 10% for each successive bills will be deducted & kept as security deposit. The security deposit will be released after expiring of defect liability period, which is 6 month from the date of completion certificate.

## **SECTION – F**

### **6. Schedule of rates**

6.1) Contractor's Remuneration: The price to be paid by the Owner to Contractor for the whole of the work to be done and the performance of all the obligations undertaken by the Contractor under the contract documents shall be ascertained by the application of the respective schedule of rates and payment to be made accordingly for the work actually executed and approved by the Officer-in-Charge. The sum so ascertained shall (excepting only as and to the extent expressly provided herein) constitute the sole and inclusive remuneration of the Contractor under the contract and no further other payment whatsoever shall be or become due or payable to the Contractor under the contract.

6.2) Rates to be Inclusive: The price/ rates quoted by the Contractor which is inclusive of all taxes, duties, levies, cess and any other taxes applicable shall remain firm till the issue of final certificate and shall not be subject to escalation. Rates shall be deemed to include and cover all costs, expenses and liabilities of every description and all risk of every kind to be taken in executing, completing and handing over the work to the Owner by the Contractor. The Contractor shall be deemed to have known the nature, scope, magnitude and the extent of the works and materials required though the contract document may not fully and precisely furnish them.

6.3) Rate to Cover Royalties, Rents and Claims: The rates shall be deemed to include and cover the cost of all royalties and fees for the articles and processes, protected by letters, patent or otherwise incorporated in or used in connection with the works, also all royalties, rents and other payments in connection with obtaining materials of

*bidder*

whatsoever kind for the works and shall include and indemnity to the Owner which the Contractor here-by gives against all actions, proceedings, claims damages, costs and expenses arising from the incorporation in or use on the works of any such articles, processes or materials. Octroi or other municipal or local board charges or any other charges if levied on materials, equipment or machineries to be brought to site for use on work shall be borne by the Contractor.

6.4) Taxes and Duties :No exemption or reduction of customs duties, excise duties, sales tax, contract quay or any port dues, transports charges, stamp duties or Central or State government or local body or Municipal Taxes or duties, taxes or charges (from or of anybody), whatsoever, will be granted or obtained, all of which expenses shall be deemed to be included in and covered by the rates. The Contractor shall also obtain and pay for all permits or other privileges necessary to complete the work.

6.5) Rates to cover Risks of Delay: The rates shall be deemed to include and cover the risk of all possibilities of delay and interference with the Contractor's conduct for work which occur from and cause including orders of the Owner in the exercise his powers and on account of extension of time granted due to various reasons and for all other possible or probable causes of delay.

## **SECTION – G**

### **7. Taxes and insurance**

7.1) Taxes, Duties, Octroi etc. : The Contractor agrees to and does hereby accept full and exclusive liability for the payment of any and all taxes, duties, octrois etc. now or hereafter imposed, increased, or modified from time to time in respect of works and materials and all contributions and taxes for unemployment compensation, insurance and old age pensions or annuities now or hereafter imposed by any Central or State governmental authorities which are imposed with respect to or covered by the wages, salaries, or other compensations paid to the persons employed by the Contractor and the Contractor shall be responsible for the compliance with all obligations and restrictions imposed by the Labor Law or any other law affecting employer-employee relationship and the Contractor further agrees to comply and to secure the compliance of all sub-Contractors, with all applicable Central State, Municipal and local laws and regulations and requirements of any Central, State or Local, Government agency or authority. Contractor further agrees to defend, indemnify and hold harmless from any liability or penalty which may be imposed by the Central, State or Local authorities by reason of any violations by Contractor or sub-Contractor of such laws, regulations or requirements and also from all claims, suits or proceedings that may be brought against the Owner arising under growing out of, or by reason of the work provided for by this contract, by third parties, or by Central or State government authority or any administrative sub-division thereof.

7.2) All taxes income tax, Duties, Levies, GST, Building and other Construction Workers Welfare Cess or any other tax or Cess in respect of this contract applicable at the time of submission of this tender shall be payable by the Contractor and the Institute shall not entertain any claim whatsoever in this respect. Taxes, GST, Cess etc. shall be deducted as per applicable rules from the bills of the contractor at the rates prevailing on the day of submission of the tender. Bids are to be submitted considering all taxes as applicable. The Institute shall reimburse service tax, if applicable, on production of paying the same. Any increase in the rates of any existing taxes/duties/levies/royalties etc shall be borne by the Institute. If there are any decreases the amounts payable will be reduced accordingly.

7.3) Other taxes: Any fresh imposition of taxes, duties, levies etc, imposed after

*Billings*

receipt of tender shall be reimbursed by the Institute on actual on production of proof of imposition of the tax.

7.4) Insurance: Contractor shall at his own expense carry and maintain insurance with reputable insurance companies to the satisfaction of the Owner as follows:

(i) Employees State Insurance Act: The Contractor agrees to and does hereby accept full and exclusive liability for compliance with all obligations imposed by the Employees State Insurance Act, 1948, and the Contractor further agrees to defend, indemnify and hold Owner harmless from any liability or penalty which may be imposed by the Central, State or Local authority by reason of any asserted, violation by Contractor or sub-Contractor of the Employees State Insurance Act, 1948, and also from all claims, suits or proceeding that may be brought against the Owner arising under, growing out of or by reasons of the work provided for by this contract whether brought by employees of the Contractor, by third parties or by Central or State Government authority or any political sub-division thereof. The Contractor agrees to fill in with the Employee's State Insurance Corporation, the Declaration Forms, and all forms which may be required in respect of the Contractors or sub-Contractors employees, whose aggregate remuneration is Rs. 15000.00 per month or such amount as prescribed under the Employees State Insurance Act, 1948 from time to time and who are employed in the work provided for or those covered by ESI from time to time under the Agreement. The Contractor shall deduct and secure the agreement of the sub-Contractor to deduct the employee's contribution as per the first schedule of the Employee's State Insurance Act form wages and affix the Employee's contribution Cards at wages payment intervals. The Contractor shall remit and secure the agreement of the sub-Contractor to remit to the State Bank of India, Employees' State Insurance Corporation. Account, the Employees contribution as required by the Act. the Contractor agrees to maintain all cards and records as required under the Act in respect of employees and payments and the Contractor shall secure the agreement of the sub-Contractor to maintain such records. Any expenses incurred for the contributions, making contributions or maintaining records shall be to the Contractor's or sub-Contractor's account. The Owner shall retain such sum as may be necessary from the total contract value until the Contractor shall furnish satisfactory proof that all contributions as required by the Employees State Insurance Act, 1948, have been paid.

(ii) Workman's compensation and employer's Liability Insurance shall be effected for all the Contractor's employees engaged in the performance of this contract. If any of the work is sublet, the Contractor shall require the sub-Contractor to provide Workman's Compensation and employer's liability insurance for the latter's employees if such employees are not covered under the Contractor's Insurance.

(iii) Any other Insurance Required Under Law or Regulations or by Owner Contractor shall also carry and maintain any and all other insurance which may be required under any law or regulation from time to time. He shall also carry and maintain any other insurance, which may be required by the Owner.

#### 7.5) Damage to Property

(i) Contractor shall be responsible for making good to the satisfaction for the Owner any loss or and any damage to all structures and properties belonging to the Owner or being executed or procured or being procured by the Owner or of other agencies within the premises of all the work of the Owner, if such loss or damage is due to fault and/or the negligence or wilful acts or omission of the Contractor, his employees, agents, representative or sub-Contractors.

(ii) The Contractor shall indemnify and keep the Owner harmless of all claims or damage to property other than Owner's property arising under or by reason of this agreement if



such claims result from the fault and/or negligence or wilful acts or omissions of the Contractor, his employees, agents representative or sub-Contractors.

## SECTION – H

### 8. Safety code

8.1) General Contractor shall adhere of safe construction practice and guard against hazardous and unsafe working conditions and shall comply with Owner's safety rules as set forth herein. Prior to start of construction, Contractor will be furnished of Owner's "Safety Code" for information and guidance, if it has been prepared.

### 8.2. First Aid and Industrial Injuries

8.2.1) Contractor shall maintain first aid facilities for his employee and those of his sub-Contractors.

8.2.2) Contractor shall make out side agreements for ambulance service and for the treatment of industrial injuries. Names of those providing these services shall be furnished to the Owner prior to start of construction and their telephone numbers shall be prominently posted in Contractor's field office.

8.2.3) All critical industrial injuries shall be reported promptly to the Owner, and a copy of Contractor's report covering each personal injury requiring the attention of a physician shall be furnished to the Owner.

8.3. General Rules : Smoking within the battery area, tank farm or dock limits is strictly prohibited. Violators of the no smoking rules shall be discharged immediately.

### 8.4) Contractor's Barricades

8.4.1) Contractor shall erect and maintain barricades required in connection with his operation to guard or protect ExcaGStions hoisting areas. Areas adjudged hazardous Contractor's or Owner's inspectors. Owner's existing property subject to damage by Contractor's operations.

8.4.2) Scaffolding: Suitable scaffolding should be provide for workmen for all works that safely be done from the ground or from solid construction except such short period work as can be done safely from ladders. When a ladder is used an extra Mazdoor shall be engaged for holding the ladder and if the ladder is used for carrying materials as well, suitable footholds and handholds shall be provided on the ladder shall be given an inclination not steeper than 1 in 4 (1 horizontal and 4 vertical).

8.5) Demolition: Before any demolition work is commenced and also during the progress of the work. All road and open areas adjacent to the work site shall either be closed or suitably protected. No electric cable or apparatus which is liable to be a source of danger shall remain electrically charged.

8.6) All practice shall be taken to prevent danger to persons employed from risk of fire or explosion or flooding. No floor, roof or other part of the building shall be so over-loaded with debris or materials as to render it unsafe.

8.7) All necessary personal safety equipment as considered adequate by the Officer-in-Charge, should be kept available for the use of the persons employed on the site and maintained in condition suitable for immediate use, and the Contractor shall take adequate steps to ensure proper use of equipment by those concerned.

8.8.1) Workers employed on mixing asphaltic materials, cement and lime mortars shall be provided with protective footwear and protective gloves.

8.8.2) Those engaged in white washing and mixing or stacking of cement bags or any materials which are injurious to the eyes shall be provided with protective goggles.

8.8.3) Those engaged in welding and cutting works shall be provided with protective face and eye shields, hand gloves etc.

8.8.4) Stone breakers shall be provided with protective goggles and protective clothing, and seated sufficiently safe intervals.

*6/11/11*



8.8.5) The Contractor shall not employ men below the age of 18 years and women on the work of painting with products containing lead in any form. Wherever men above the age of 18 years are employed on the work of lead painting, the following precautions should be taken.

8.9) No paint containing lead or lead product shall be used except in the form of paste or ready-made paint. Suitable face masks should be supplied for use by the workers when Paints is applied in the form of spray or a surface having lead paint dry rubbed and scrapped.

8.10) Overalls shall be supplied by the Contractor to the workmen and adequate Facilities shall be provided to enable the working painters to wash them during and on cessation of.

8.11) When the work is done near any place where there is a risk of drowning, all Necessary safety equipment should be provided and kept ready for use and all necessary steps taken for prompt rescue of any person in danger and adequate provision should be made for prompt first aid treatment of all injuries likely to be sustained during the course of the work.

8.12) Use of hoisting machines and tackles including their attachments, anchorage and supports shall of good mechanical construction, sound materials and adequate strength and free from patent defect and shall be kept in good working order.

8.13) When workers are employed on electrical installations which are already energized, insulating mats, wearing apparel, such as gloves, sleeves, and boots as may be necessary should be provided.

8.14) All scaffolds, ladders and other safety devices mentioned or described herein shall be maintained in safe conditions and no scaffold, ladder or equipment shall be altered or removed while it is in use.

8.15) These safety provisions should be brought to the notice of all concerned by the displaying on a notice board at a prominent place at the work-spot. The person responsible for compliance of the safety code shall be named therein by the Contractor.

8.16) To ensure effective enforcement of the rules and regulations relating to safety precautions, the arrangements made by the Contractor shall be open to inspection by the Welfare Officer, Officer-in-Charge or safety Engineer of the administration or their representatives.

#### **4.0 Technical specification:**

4.1 The works shall be carried out in conjunction with specifications, schedule of item and the construction drawings issued from time to time. The latest edition of the specifications given in Central Public Works Department (CPWD) 2020-21

4.2 In interpreting the specifications the following sequence shall be followed unless otherwise given in writing by the Engineer-in-charge:

(a) Nomenclature of items of the schedule of items.

(b) Drawings and working details.

(c) Technical Specifications given in the tender

In absence of the specifications in any of the above, the specifications furnished by the Officer-in-Charge based on sound engineering practices shall be final and binding.

4.3 The schedule of quantities, the structural and Architectural drawings shall be properly co-related and all these documents should be read and operated in harmonious conjunction. In case of any discrepancy in items given in the Schedule of Quantities appended with the tender and architectural drawings relating to relevant item the former shall prevail unless otherwise given in writing by the Officer-in-Charge.

4.4 All the works shall be carried out in sound workmanship and true to line, level, plumb and as per the best practice of the trade.

*Subm*

4.5 All materials to be supplied by the contractor shall be new. All packed items shall arrive at site in original packing only. Any items found defective or damaged shall be replaced by the contractor at his own expenses. The sources of materials stated in the specifications are those from which materials are generally available. However, materials not conforming to specifications shall be rejected even if they come from the stated source. The contractor should satisfy himself that sufficient quantity of material of acceptable specification is available from the stated or other sources.

4.6 All the materials brought at site shall be stored and stacked in a proper manner. The materials requiring protection from the sun and rain shall be kept inside the temporary structures to be erected at site by the contractor. The contractor shall also follow the manufacturer's instructions for storing and stacking the materials. The storage facilities are to be created by the contractor at his own expense. The contractor shall consult the Officer-in-Charge regarding collection and stacking of basic materials required for the work. They should not stack any materials in any place other than those approved by the Officer-in-Charge within the plot area. On completion of the work the area used will be restored, properly dressed to satisfaction of the Officer-in-Charge at no extra cost

4.7 The contractor shall be responsible for co-coordinating the work with works of other trades sufficiently ahead of time to avoid unnecessary hold ups. Hangers, sleeves, recesses etc. shall be left in time as the work proceeds.

4.8 A site order book will be kept at the site of the work in which instructions shall be recorded by Site Engineer / Architect or their representatives. The contractor or his authorized agent shall sign the site order book to acknowledge the instructions in all events and follow the same.

4.9 All works shall be adequately protected, to the satisfaction of the Officer-in-Charge, so that same is free from damage throughout the period of construction up to the time of handing over. Special care must be taken to prevent damage and scratching of all fittings and fixtures. Tool marks on exposed fixtures shall not be accepted. Protective paper on fixtures shall be removed with hot water only at the final completion of the work. Before handing over the possession of work, the contractor shall clean all elements of the complete installation, remove plasters, splashier, stickers, rust stains and other foreign matter and leave every part in acceptable condition and ready for use to the satisfaction of the Officer-in-Charge/ Architect.

4.10 Rates for all items in which use of cement is involved, is inclusive of charges for curing.

*Eds*

Approved list of materials

Sl. No.	Description of Materials	Approved Brand of Materials
1	Cement	Ultratech/Lafarge/Ambuja/Topcem
2	Putty	JK White/Birla
3	Paint	Berger/ Asian Paints
5	TMT Bar,Grill	Tata/Sail/Shyam/Jindal
6	M.S for truss work	Tata
7	Wood	Saal, Gamari
8	W.C.	Parryware,Jaquar
9	Stop Cock,Bib Cock, Tap etc	Jaquar.Hindware
10	Pipes	Supreme

*File*  
*11.12.22*

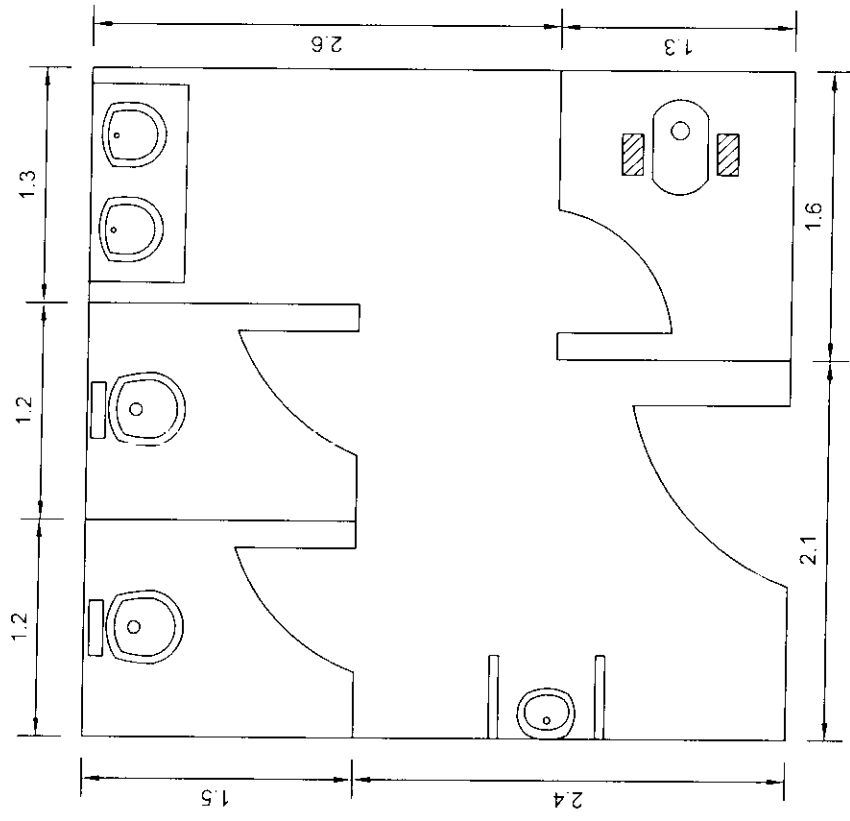

1st floor Toilet ( Botany Department )  
 Total Floor Area = 14.43 sqm  
 Total Wall Area = 61.80 sqm

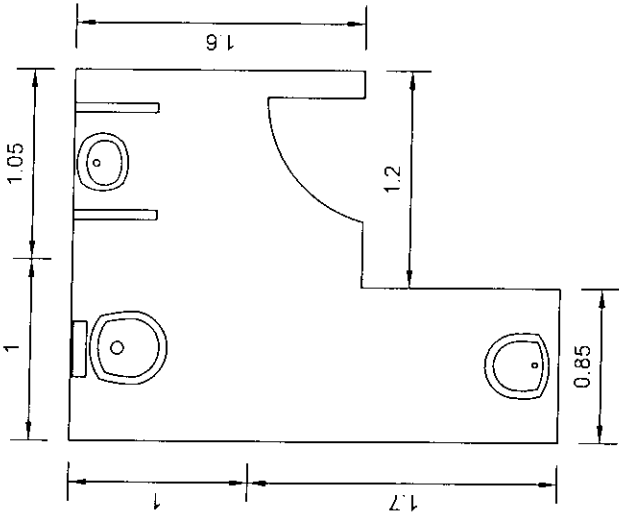

Ground floor Toilet ( Botany Department )  
 Total Floor Area = 4.22 sqm  
 Total Wall Area = 28.5 sqm

*Handwritten signature*

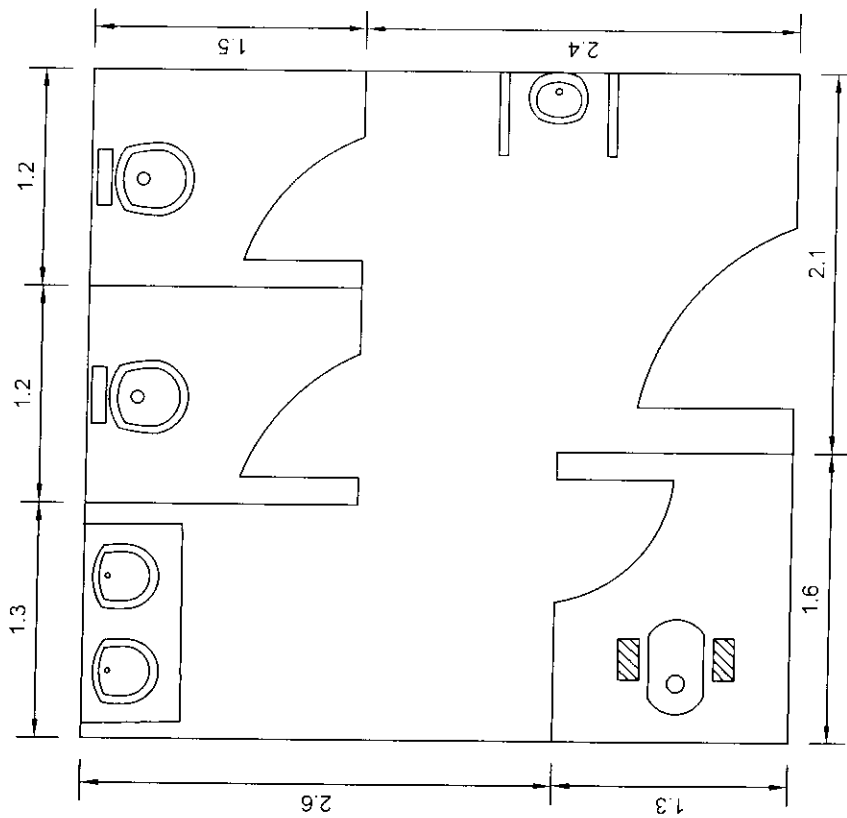

1st floor Toilet ( Botany Department )  
 Total Floor Area = 14.43 sqm  
 Total Wall Area = 61.80 sqm

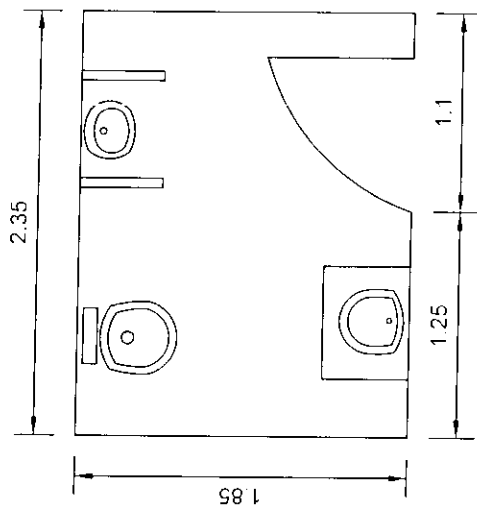

Ground floor Toilet ( Botany Department )  
 Total Floor Area = 4.35 sqm  
 Total Wall Area = 25.2 sqm

*6/1/13*

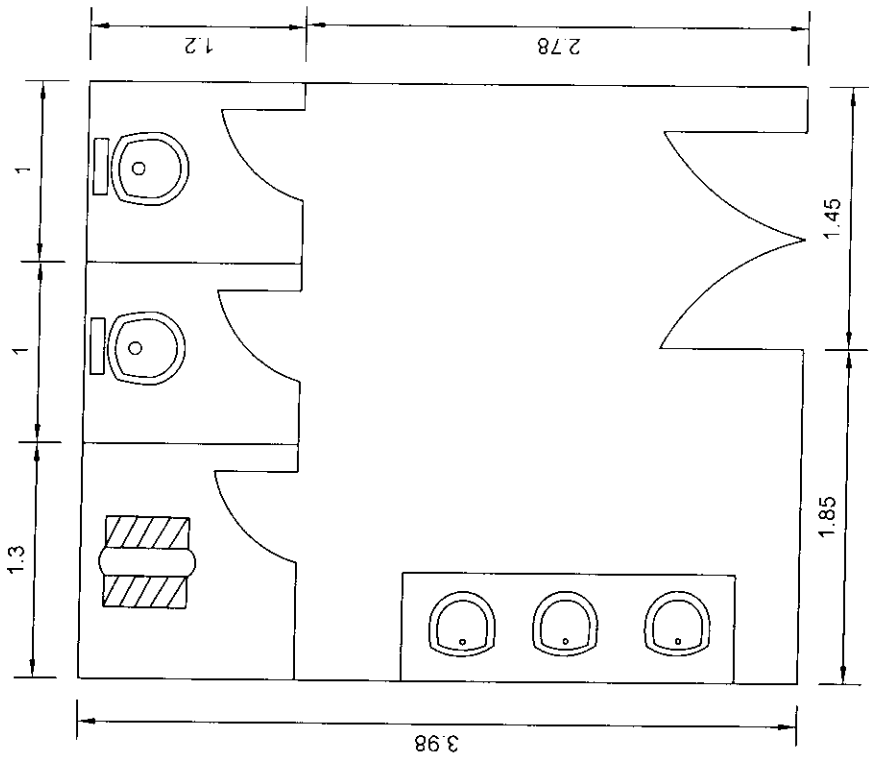

1st floor Toilet ( Botany Department )  
 Total Floor Area = 13.13 sqm  
 Total Wall Area = 50.88 sqm

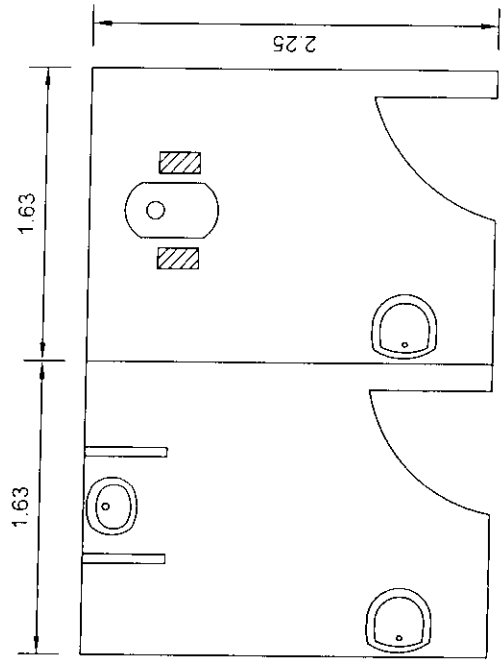

Staff Toilet (Botany Department)  
 Total Floor Area = 7.31 sqm  
 Total Wall Area = 33.125 sqm

*Edwards*

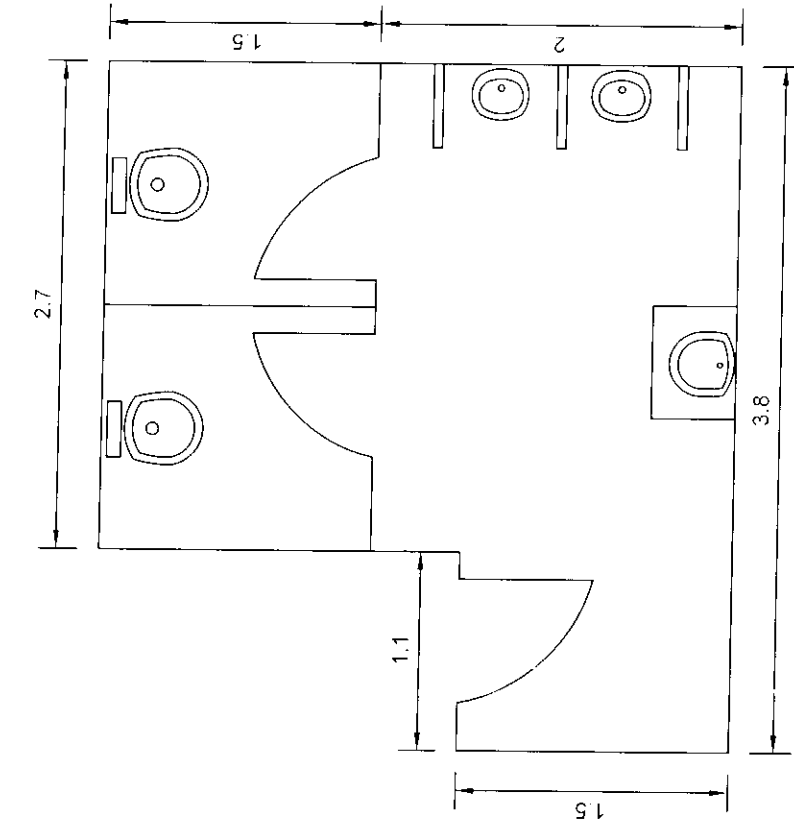

2nd floor Toilet ( Botany Department )  
 Total Floor Area = 11.10 sqm  
 Total Wall Area = 51.3 sqm

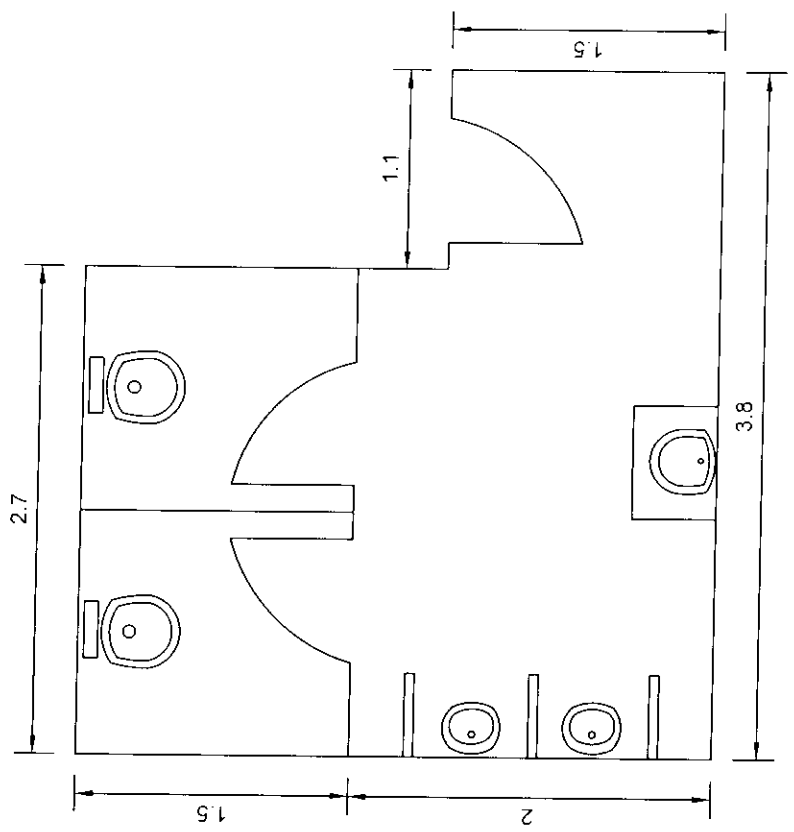

2nd floor Toilet ( Botany Department )  
 Total Floor Area = 11.10 sqm  
 Total Wall Area = 51.3 sqm

*blm*

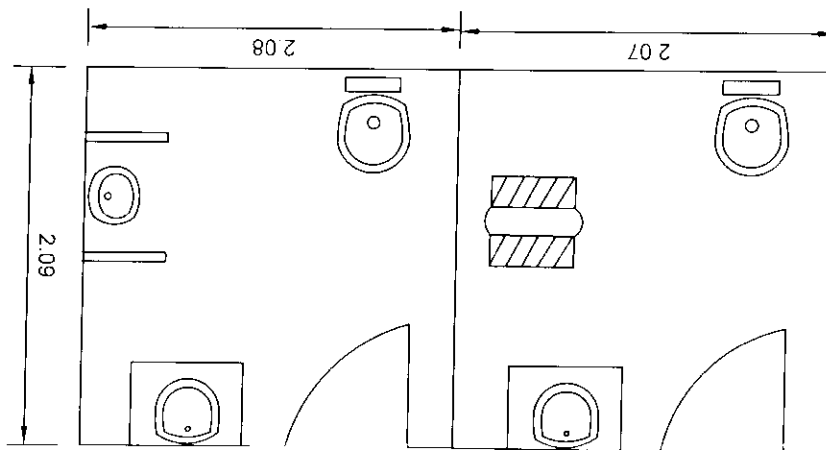

Gents Toilet (Zoology Department)  
 Total Floor Area = 8.71 sqm  
 Total Wall Area = 44.10 sqm

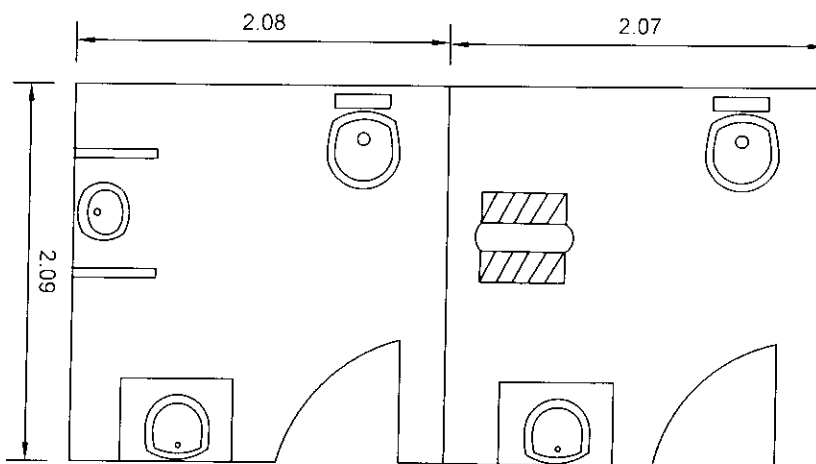

Ladies Toilet (Zoology Department)  
 Total Floor Area = 8.71 sqm  
 Total Wall Area = 44.10 sqm

*tdms*



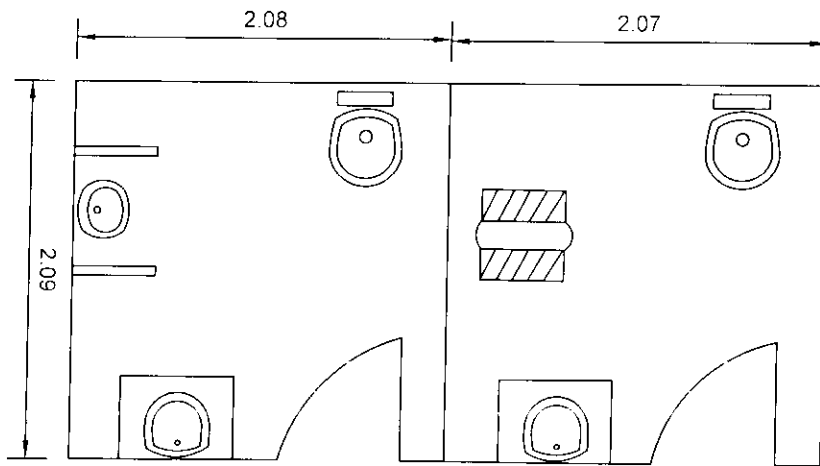

2nd floor Toilet (Zoology Department)  
 Total Floor Area = 8.71 sqm  
 Total Wall Area = 44.10 sqm

Old Toilet (Zoology Department)  
 Total Floor Area = 4.36 sqm  
 Total Wall Area = 22.05 sqm

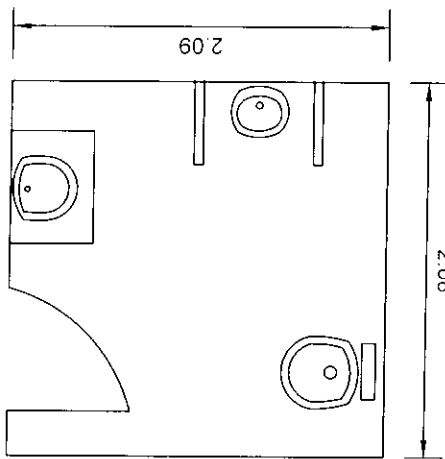

*Handwritten signature*

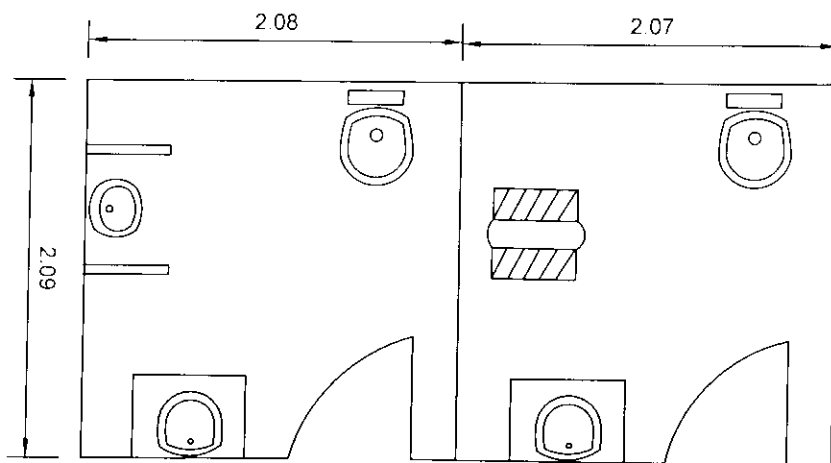

2nd floor Toilet (Zoology Department)  
Total Floor Area = 8.71 sqm  
Total Wall Area = 44.10 sqm

*6/1/20*

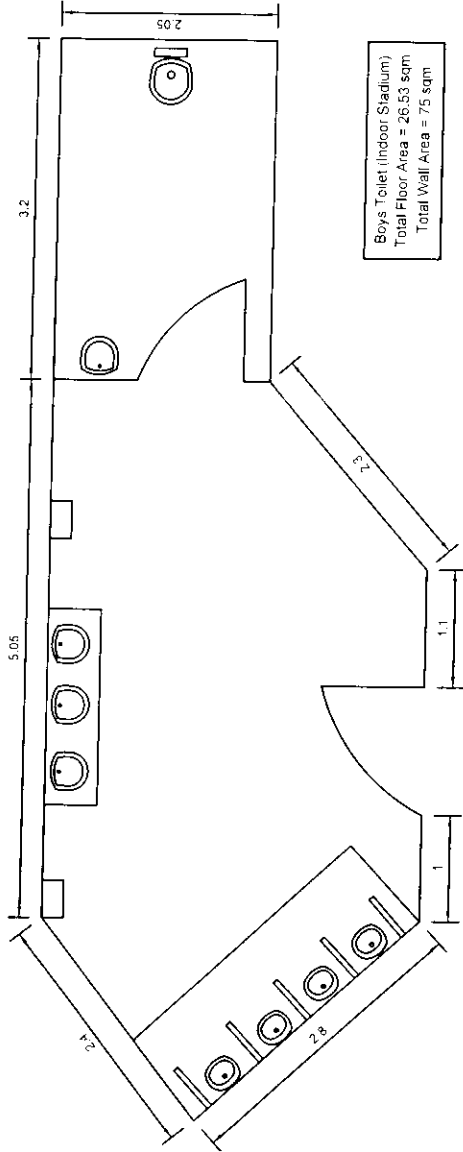

Boys Toilet (Indoor Stadium)  
 Total Floor Area = 26.53 sqm  
 Total Wall Area = 75 sqm

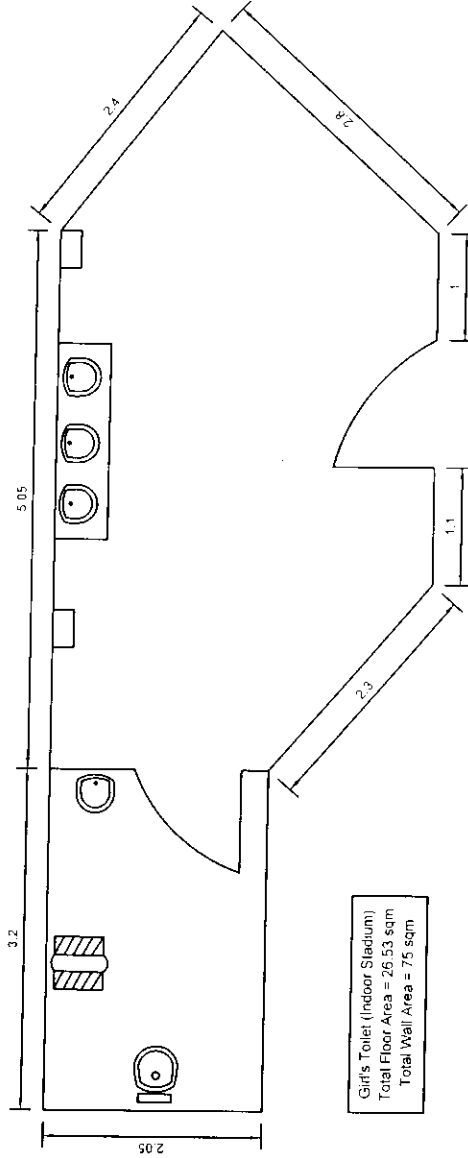

Girls Toilet (Indoor Stadium)  
 Total Floor Area = 26.53 sqm  
 Total Wall Area = 75 sqm

Gulm

**PRICE-BID**  
**Renovation of Toilet Blocks of Zoology, Botany and Indoor Stadium**

Description of Work	Unit	Quantity	Rate in Figures	Rate in Words	Amount
<b>Demolishing</b> Demolishing cement concrete manually/ by mechanical means including disposal of material within 50 metres lead as per direction of Engineer - in - charge.	cum	23			
Demolishing R.C.C. work manually/ by mechanical means including stacking of steel bars and disposal of unserviceable material within 50 metres lead as per direction of Engineer - in- charge.	cum	15			
Demolishing brick work manually/ by mechanical means including stacking of serviceable material and disposal of unserviceable material within 50 metres lead as per direction of Engineer-in-charge.	cum	15			
Dismantling doors, windows and clerestory windows (steel or wood) shutter including chowkhats, architrave, holdfasts etc. complete and stacking within 50 metres lead :					
Door	no	19			
Window		7			
Taking out doors, windows and clerestory window shutters (steel or wood) including stacking within 50 metres lead :					
Door	no	19			
Window		7			
Dismantling wood work in frames, trusses, purlins and rafters up to 10 metres span and 5 metres height including stacking the material within 50 metres lead :	cum	6			
Dismantling steel work manually/ by mechanical means in built up sections without dismembering and stacking within 50 metres lead as per direction of Engineer	kg	570			

*tdm*

**PRICE-BID**  
**Renovation of Toilet Blocks of Zoology, Botany and Indoor Stadium**

Dismantling tile work in floors and wall laid in cement mortar including stacking material within 50 metres lead.	sqm	494.17	
Dismantling old plaster or skirting raking out joints and cleaning the surface for plaster including disposal of rubbish to the dumping ground within 50 metres lead.	sqm	374.9	
Dismantling and removing the existing European type W.C. wash basin and squatting plate urinal without damaging the walls and removing the frame and necessary repairs to the edge of the walls as directed for all levels.	no	14	
<b>CIVIL WORKS</b>			
Repairs to plaster of thickness 12 mm to 20 mm in patches of area 2.5 sq.meters and under, including cutting the patch in proper shape,raking out joints and preparing and plastering the surface of the walls complete, including disposal of rubbish to the dumping ground, all complete as per direction of Engineer-in-Charge.	sqm	374.9	
Half brick masonry with common burnt clay F.P.S. (non modular) bricks of class designation 7.5 in superstructure above plinth level up to floor V level.	sqm	47.7	
Steel reinforcement for R.C.C. work including straightening, cutting, bending, placing in position and binding all complete above plinth level.	kg	200	
Providing and laying cement concrete in retaining walls, return walls,walls (any thickness) including attached pilasters, columns, piers, abutments, pillars, posts, struts, buttresses, string or lacing courses,parapets, coping, bed blocks, anchor blocks, plain window sills, fillets, sunken floor etc., up to floor five level,			
M20	cum	2	

*Handwritten signature*

**PRICE-BID**  
**Renovation of Toilet Blocks of Zoology, Botany and Indoor Stadium**

<p>Providing and laying Vitrified tiles in floor with different sizes (thickness to be specified by the manufacturer), with water absorption less than 0.08% and conforming to IS:15622, of approved brand &amp; manufacturer, in all colours and shade, laid with cement based high polymer modified quick set tile adhesive (water based) conforming to IS : 15477, in average 6 mm thickness, including grouting of joints</p>			
<p>Size of Tile 600x600 mm</p>			
<p>Providing and fixing 1st quality ceramic glazed wall tiles conforming to IS: 15622 (thickness to be specified by the manufacturer), of approved make, in all colours, shades except burgundy, bottle green, black of any size as approved by Engineer-in-Charge.</p>	sqm	215	
<p>30 mm thick factory made Polyvinyl Chloride (PVC) door shutter made of styles and rails of a uPVC hollow section of size 60x30 mm and wall thickness 2 mm (<math>\pm</math> 0.2 mm), with inbuilt decorative moulding edging on one side.</p>	sqm	40	
<p>Providing and fixing factory made single extruded WPC (Wood Polymer Composite) solid door/window/Ceoseatory windows &amp; other Frames/Chowkhat comprising of virgin PVC polymer of K value 58- 60 (Suspension Grade), calcium carbonate and natural fibers (wood powder/ rice husk/wheat husk) and non toxic additives.  Frame size 65 x 125 mm</p>	meter	152	
<p>Providing and fixing factory made single extruded WPC (Wood Polymer Composite) solid plain flush door shutter of required size comprising of virgin polymer of K value 58-60 (Suspension Grade), calcium carbonate and natural fibers (wood powder/ rice husk/wheat husk) and non toxic additives (maximum toxicity index of 12 for 100 gms)  30 mm thick</p>	sqm	30	

*Handwritten signature*

**PRICE-BID**  
**Renovation of Toilet Blocks of Zoology, Botany and Indoor Stadium**

Painting with synthetic enamel paint of approved brand and manufacture of required colour to give an even shade :	sqm	187.45		
Applying one coat of water thinnable cement primer of approved brand and manufacture on wall surface :	sqm	187.45		
Water thinnable cement primer				
Providing and fixing aluminium die cast body tubular type universal hydraulic door closer (having brand logo with ISI, IS : 3564, embossed on the body, door weight upto 35 kg and door width upto 700 mm), with necessary accessories and screws etc. complete.	nos	15		
Providing and fixing aluminium handles, ISI marked, anodised (anodic coating not less than grade AC 10 as per IS : 1868) transparent or dyed to required colour or shade, with necessary screws etc. complete :	nos	14		
Providing and fixing white vitreous china pedestal type water closet (European type) with seat and lid, 10 litre low level white vitreous china flushing cistern & C.P. flush bend with fittings & C.I. brackets, 40 mm flush bend,	nos	23		
W.C. pan with ISI marked white solid plastic seat and lid				
Providing and fixing white vitreous china flat back half stall urinal of size 580x380x350 mm with white PVC automatic flushing cistern, with fittings, standard size C.P. brass flush pipe, spreaders with unions and clamps (all in C.P. brass) with waste fitting	meter	11		
Single half stall urinal with 5 litre P.V.C. automatic flushing cistern				

*Eshu*

**PRICE-BID**  
**Renovation of Toilet Blocks of Zoology, Botany and Indoor Stadium**

Poly propylene- Random - Co - Polymer (PPR) pipes PN-16 (SDR 7.4) - 25 mm Outer dia	meter	70									
Poly propylene- Random - Co - Polymer (PPR) pipes PN-16 (SDR 7.4) - 32 mm Outer dia	meter	78									
Providing and fixing Chlorinated Polyvinyl Chloride (CPVC) pipes, having thermal stability for hot & cold water supply including all CPVC plain & brass threaded fittings 100 mm nominal dia Pipes	meter	32									
50 mm nominal dia CPVC Pipes 32 mm nominal dia CPVC Pipes 25 mm nominal dia CPVC Pipes 15 mm nominal dia CPVC Pipes	<table border="1" style="width: 100%; text-align: center;"> <tr><td>metre</td></tr> <tr><td>metre</td></tr> <tr><td>metre</td></tr> <tr><td>metre</td></tr> </table>	metre	metre	metre	metre	<table border="1" style="width: 100%; text-align: center;"> <tr><td>45</td></tr> <tr><td>53</td></tr> <tr><td>32</td></tr> <tr><td>46</td></tr> </table>	45	53	32	46	
metre											
metre											
metre											
metre											
45											
53											
32											
46											
Providing and fixing wash basin with C.I. brackets, 15 mm C.P. brass pillar taps, 32 mm C.P. brass waste of standard pattern, including painting of fittings and brackets, cutting and making good the walls wherever require: White Vitreous China Wash basin size 550x400 mm with a pair of 15 mm C.P. brass pillar taps	nos	20									

*Handwritten signature*



**PRICE-BID**  
**Renovation of Toilet Blocks of Zoology, Botany and Indoor Stadium**

Providing and fixing P.V.C. waste pipe for sink or wash basin including P.V.C. waste fittings complete. 32 mm dia	meter	20	
Providing and fixing C.P. brass long nose bib cock of approved quality conforming to IS standards and weighing not less than 810 gms. 15 mm nominal bore	nos	20	
Providing and fixing wash basin with C.I. brackets, 15 mm PTMT pillar cock, 32 mm PTMT waste coupling of standard pattern, including painting of fittings and brackets, cutting and making good the walls wherever required. White Vitreous China Flat back wash basin size 550x400 mm with single 15 mm PTMT pillar cock.	each	20	
Providing and fixing C.P. brass stop cock (concealed) of standard design and of approved make conforming to IS:8931. 15 mm nominal bore	Each	20	
Providing and fixing white vitreous china squatting plate urinal with integral rim longitudinal flush pipe.	Each	6	
Providing and fixing controlled flush, low level cistern made of vitreous china with all fittings complete. 10 litre (full flush) capacity-white	Each	18	
Providing and fixing mirror of superior glass (of approved quality) and of required shape and size with plastic moulded frame of approved make and shade with 6 mm thick hard board backing :	nos	10	
	nos	10	
Oval shape 450x350 mm (outer dimensions)			
Rectangular shape 453x357 mm			

*Handwritten signature*

**PRICE-BID**  
**Renovation of Toilet Blocks of Zoology, Botany and Indoor Stadium**

Providing and fixing white vitreous china pedestal for wash basin completely recessed at the back for the reception of pipes and fittings.	Each	20		
Providing and fixing PTMT soap Dish Holder having length of 138mm, breadth 102mm, Height of 75mm with concealed fitting arrangements, weighing not less than 106 gms.	Each	20		
Providing and fixing Polyethelene-Aluminium- Polyethelene PE-ALPE Composite Pressure Pipes conforming to IS - 15450, (16 mm OD) pipe	meter	28		

(In Words.....Only)

Place:

Date:

Seal & Signature of the tenderer

